



Tm2 Series

Electric Operating Mechanism





2016 Edition

Nader

CONTENTS

■ Product Overview	1-2
■ Scope of Application	1-2
■ Application Scope	1-3
■ Technical Characteristics of The Product	1-4
■ Appearance and Installation Dimension	1-5
■ Product Wiring Diagram	1-5
■ Package and Storage	1-6
■ Matters Needing Attention	1-6

1. Product Overview

Picture				
Specifications	Tm2/1P	Tm2/2P	Tm2/3P	Tm2/4P
Adaptation	NDB2-63/1P NDB2Z-63/1P NDB2T-63/1P NDB2LE-63/1PN	NDB2-63/2P NDB2Z-63/2P NDB2T-63/2P NDB2LE-63/2P	NDB2-63/3P NDB2Z-63/3P NDB2T-63/3P NDB2LE-63/3P	NDB2-63/4P NDB2Z-63/4P NDB2T-63/4P NDB2LE-63/3PN/4P

Tm	2 / □ / □	
1	2	3
1	2	3
Serial No.	Description of Serial Number	Tm2
1	Product code	Remote control
2	Design serial No.	2
3	Voltage specification	12、24、48、110、230
4	Number of poles	1、2、3、4

2. Scope of Application

- ◆ Accessories of NDB2-63, NDB2Z-63, NDB2T-63 and NDB2LE-63 series products
- ◆ Mainly used for communication, transportation, new energy, intelligent control and other fields requiring remote control

3. Application Scope

3.1 Installation way

Install with TH35mm standard installation rail,
tunnel type wiring terminal used for wiring

3.2 Installation direction

360 ° installation, flexible installation direction

3.3 Environmental protection requirements

Products meet the ROHS standard

3.4 Altitude requirements

≤4000m

3.5 Humidity and heat resistance

Alternating hot and humid (At the temperature of +55°C, the relative humidity is 95%)

3.6 Working environment

-40 ~ +70°C

3.7 Pollution class

3

3.8 Other extensions (Legend)

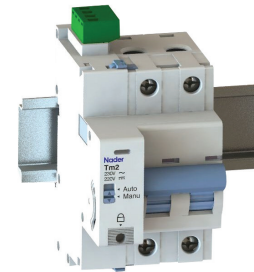
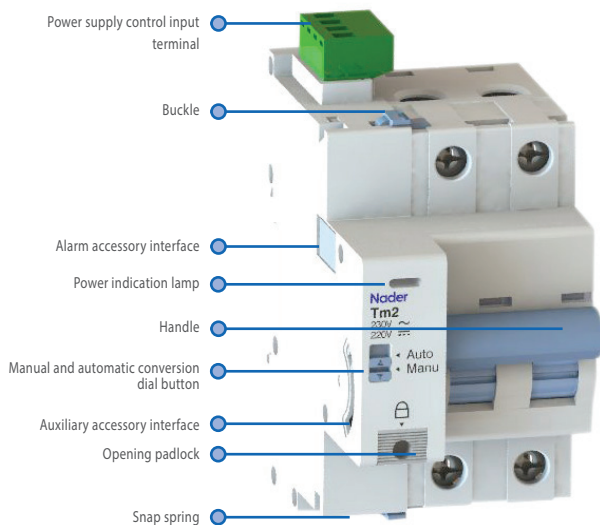

35mm standard guide rail installation

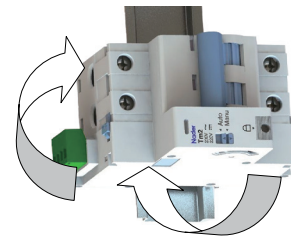

360° installation

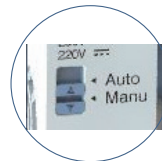

Legend

Auto	Auto remote close-open circuit breaker
Manu	Manu local close-open circuit breaker



Legend

Padlock	Disconnect all remote operations, padlock size $\Phi \leq 4\text{mm}$
---------	--



Legend

Alarm accessory interface	Assembly model SD2
Auxiliary accessory interface	Assembly model OF2

Remarks:

1. After the assembly of Tm2 and circuit breaker body, assemble other accessories;
2. The left side of Tm2 can be assembled with 2 SD2 or 2 OF2 or 1 SD2, 1 OF2
3. Tm2 can be assembled with SD2 and ATm to reclose the circuit breaker after fault

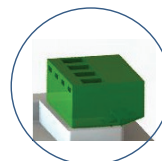

Legend

Socket type terminal	Maximum wiring capacity of ports 1~4 is 2.5mm ² (24-14AWG) and wiring capacity 0.56N·m
----------------------	---

4. Technical Characteristics of The Product

4.1 Purpose

- ◆ Used in control voltage DC12V, DC24V, DC48V, DC110V, DC220V, AC110V and AC230V circuits to provide the remote closing/breaking control of circuit breakers
- ◆ Handle can be used to provide local control of circuit breakers
- ◆ Padlock accessories can be used to lock the opening of circuit breaker to ensure safe operation at the site

4.2 Technical parameters

Parameter Name	Description of Specific Parameters									
Number of poles	1P/2P					3P/4P				
Width (mm)	18					27				
Control voltage (V)	AC230/ DC220	AC110/ DC110	DC48	DC24	DC12	AC230/ DC220	AC110/ DC110	DC48	DC24	DC12
Start power consumption (W)	46	33	48	36	36	46	33	48	36	36
Operating current (A)	≤0.2	≤0.3	≤1	≤1.5	≤3	≤0.2	≤0.3	≤1	≤1.5	≤3
Insulation voltage (V)	500					500				
Closing or opening time (s)	≤0.5					≤0.5				
Operating life (Times)	20000					20000				
Protection grade	IP20					IP20				
Models which can be assembled	NDB2-63/1P、NDB2Z-63/1P、 NDB2T-63/1P、NDB2LE-63/1PN					NDB2-63/3P、NDB2Z-63/3P、 NDB2T-63/3P、NDB2LE-63/3P				
	NDB2-63/2P、NDB2Z-63/2P、 NDB2T-63/2P、NDB2LE-63/2P					NDB2-63/4P、NDB2Z-63/4P、 NDB2T-63/4P、NDB2LE-63/3PN/4P				
Weight (g)	107					123				
Mechanical shock resistance	Half-wave sine pulse peak acceleration: 300m/s ² ; shock pulse period: 11ms; 3 shocks									
Vibration resistance	Frequency range: 10~150Hz; acceleration: 3g									

5. Appearance and Installation dimension

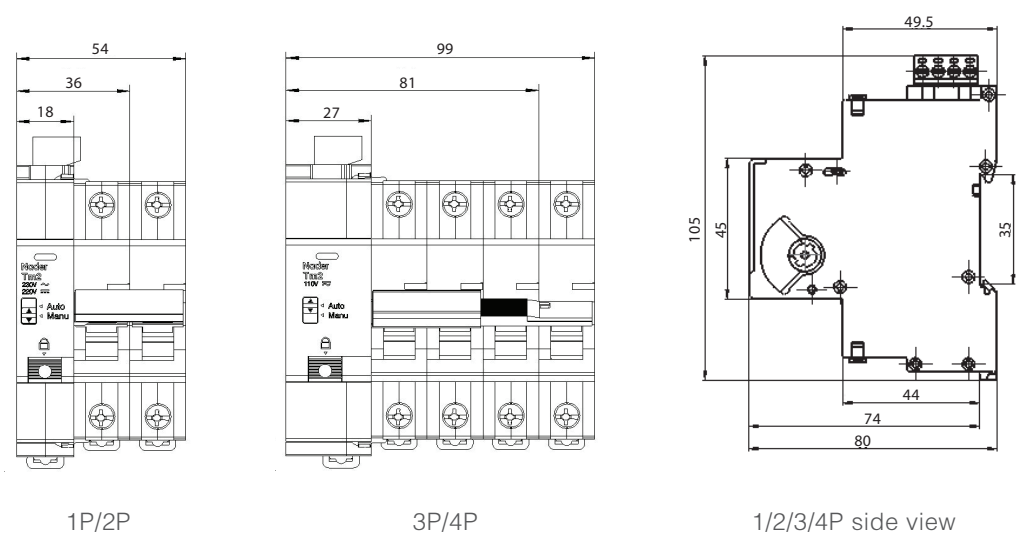

6. Product Wiring Diagram

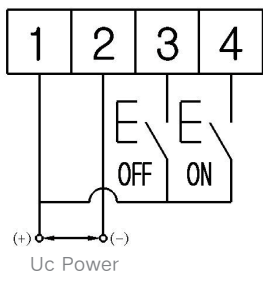

Note: When the power supply is DC, the positive and negative electrodes cannot be reversed; when the power supply is AC, the positive and negative electrodes may be freely wired

7. Package and Storage

The existing NDB2LE–63 packaging crates, boxes and plastic bags of our company are used for packaging. Products in packaging boxes should be stored in the warehouse where air circulation and relative humidity are less than 80% and temperature is neither higher than +60°C nor lower than –25°C. And the warehouse should be free from acidic, alkaline or other corrosive gases in the ambient air. Under the above–mentioned conditions, the storage period is not more than three years from the date of production.

8. Matters Needing Attention

- ◆ The product must be installed by the personnel with professional qualification. The body of the product may not be disassembled without the permission of the manufacturer. Quality problems caused by unauthorized disassembly of the product should be at your own risk.
- ◆ Do not touch the product when it is powered on to avoid any possible electric shock event.
- ◆ In case of tripping of circuit breaker due to possible fault of protection circuit (overload or short circuit), it is a must to switch the electric operating mechanism to the manual status, find out the causes, eliminate the fault and restore to the automatic status.
- ◆ In case of normal maintenance or troubleshooting of load side line, the electric operating mechanism must also be returned to the manual status first.
- ◆ Please do not debug the product without permission. Any product quality problems incurred therefrom will not be the responsibility of the manufacturer.